

Sized draw standard version: CL R Measures without tolerance according to UNI ISO 2768-mk

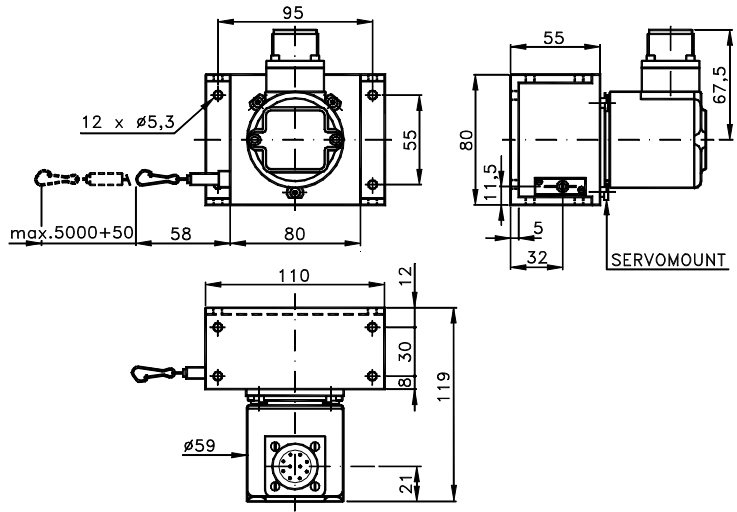

TECHNICAL FEATURES AND POSSIBLE CONFIGURATIONS

- Standard length.....: 5000 mm (*)
 - Resolution.....: 0,1 mm, 1 mm (*)
 - Weight.....: 950 g
 - Pullout cable force.: 7,1 N
 - Pullin cable force..: 3,2 N
 - Max acceleration....: 5 G
 - Max linearity error.: ±0,04% f.s. (*)
 - Max reading speed...: 10 m/s
 - Protection class....: encoder: IP64 mecc.: IP43 (°)
output: see 'CONNECTION' page
 - Ball bearings life....: 1,5 x 10⁹ revolutions
 - Impact resistance....: 50 G x 11ms
 - Vibration resistance.: 12 G (10 ÷ 2000 Hz)
 - Operating temperature: 0 ÷ 70 °C (*)
 - Storage temperature..: -30 ÷ 85 °C
 - Max frequency.....: 100 kHz
 - Max consumptions mA.: std 120 line driver 180 (*)
 - Light source.....: LED with >= 100000 h life
 - Cable.....: Ø 0,5 mm stainless steel
- (°) IP according to CEI EN 60529, EN 60529, IEC 529 (*) custom options

ELECTRONICS

CODE	DESCRIPTION	mA	CODE	DESCRIPTION	mA	CODE	DESCRIPTION	mA	COD.	DESCRIPTION
K	STANDARD NPN	10	N	DRIVER 26LS31	30	Y	SINUSOID. 1Vpp	10	W	
Q	NPN OPEN COLL	10	T	TTL 7404	10				6	
R	NPN	70	C	DRIVER 88C30	20				7	
P	NPN OPEN COLL	70	L	2x PUSH-P. PRO	70					
U	PNP	70	M	2x PUSH-PULL	70					
B	PNP OPEN COLL	70	6	Iu = 4±20 mA						
H	PUSH-PULL PRO	70	W	1K POTENTIOM.						
	PUSH-PULL	70								

Tolerance between phases ± 25°, symmetry ± 15°

(§) Clock-wise output rotation (see shaft).



Elcis encoder s.r.l. Via Rosa Luxembourg 12/14 10093 COLLEGNO (TO) ITALY
Phone: +39 011 715577/78 a.r.
MAIL: ELCIS s.r.l. P.O.Box 70 10093 COLLEGNO (TO) ITALY

* <http://www.elcis.com>
* e-mail: info@elcis.com
* Fax: +39 011 712613

POSSIBLE OPTIONS				POSSIBLE CONNECTIONS								
CODE	DESCRIPTION	CODE	DESCRIPTION	CABLE				OUTPUT				
B	Low temperature Unbreakable disk	B	Low consumption	CV				AX				
Y		K	Invert. phase A,B,Zero.	CONNECTOR				RAD				
		J	Zero logic combination	CM	SM	CL	SL	CD	CH	CH5	CI	AX
		M	Impregnated electronic	CE			C4	CH6				RAD
		A	High temperature	CABLE END CONNECTOR				OUTPUT				
X	Custom Options			VM	TM	VL	TL	VD	VH	VH5	VI	AX
				VE	VK	TK	VN	VH6	VM5	VM9	VS	RAD
				VD5	TERMINAL BOX				OUTPUT			
				MS				AX				

ORDERING INFORMATION

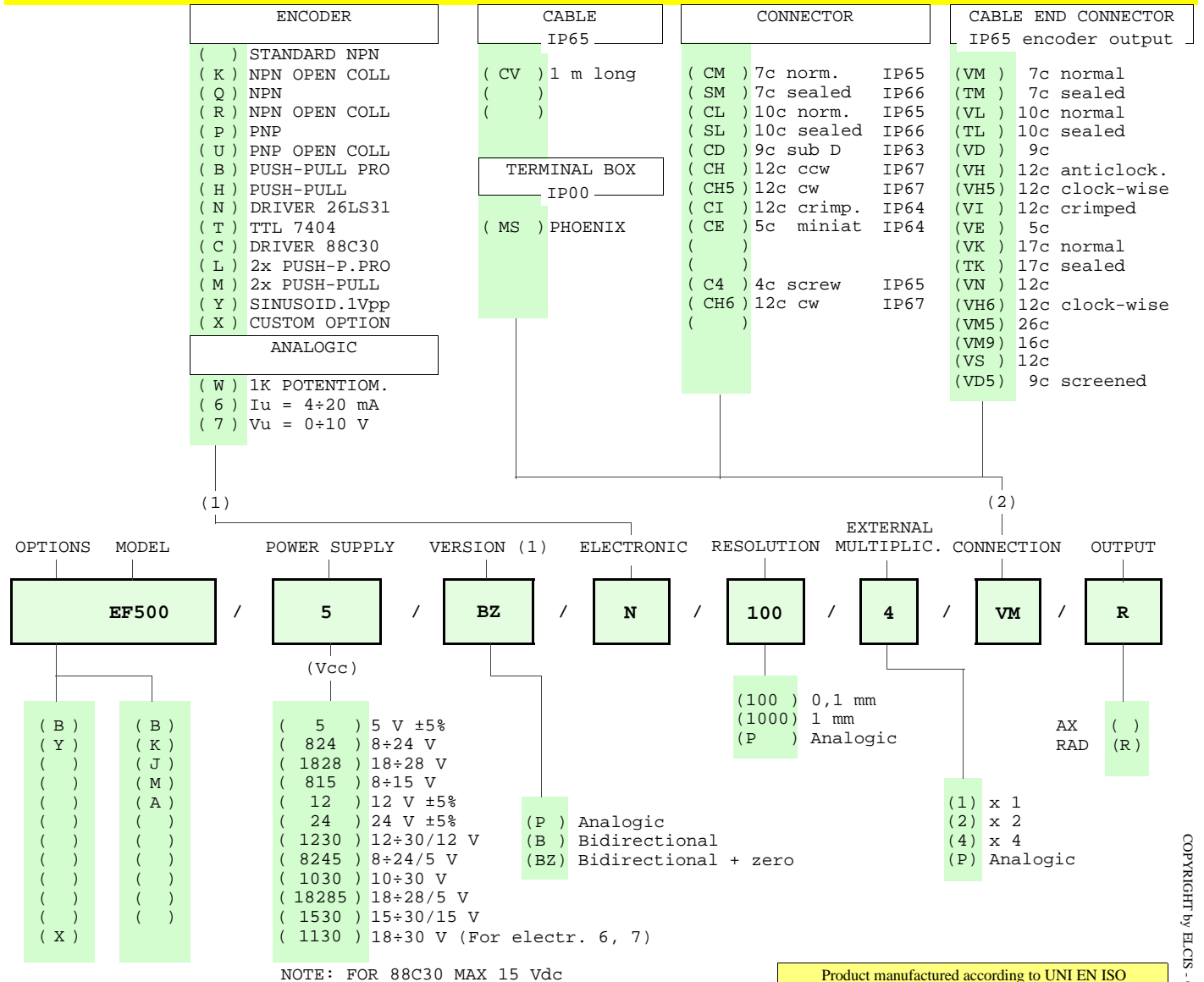

(1) For further information see ELECTRONIC data sheet
(2) For further information see CONNECTION data sheet

Product manufactured according to UNI EN ISO 9001:2008, supplied with CHECKING and CONFORMITY declaration with CE mark and with TWO (2) YEARS WARRANTY starting from delivery date.

	Elcis encoder s.r.l. Via Rosa Luxembourg 12/14 10093 COLLEGNO (TO) ITALY Phone: +39 011 715577/78 a.r. MAIL: ELCIS s.r.l. P.O.Box 70 10093 COLLEGNO (TO) ITALY	* http://www.elcis.com * e-mail: info@elcis.com * Fax: +39 011 712613
--	--	---

COPYRIGHT by ELCIS - Collegno (TO)