

**ABSOLUTE  
ENCODER  
WITH FIELD BUS  
958HC**

Compact absolute encoder for industrial ambients. CANopen interface.  
'Servo-mount' installation by means of claws or frontal screws.  
High resolution and very good quality/price ratio.

Absolute with field bus  
page: 08.958HC 1/2  
data sheet IB 023 E00

Measures without tolerance acc. to UNI ISO 2768-mk

CANopen

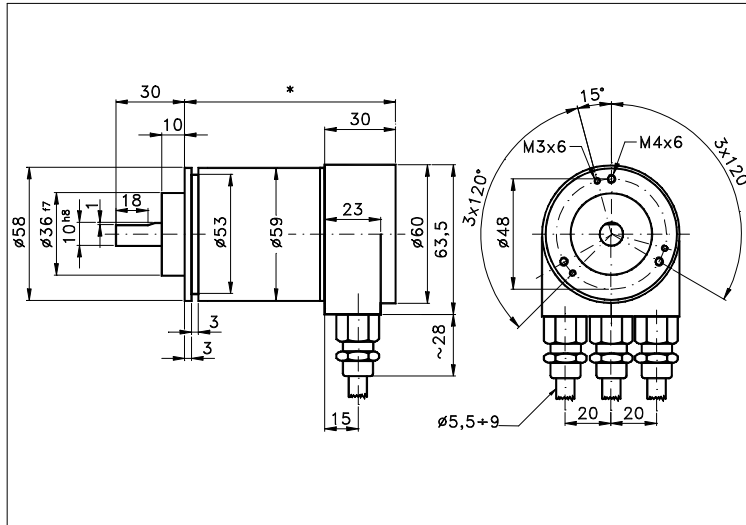

\* 82 Singleturn, 92 Multiturn

**TECHNICAL FEATURES AND POSSIBLE CONFIGURATIONS**

- Outout codes.....: Binary
- Max resolut.....: 16 bit/1 rev.  
: 30 bit/16384 rev.
- Pulses/rev.....: (12) 4096, (13) 8192,  
(14) 16384, (15) 32768,  
(16) 65536.
- No. of rev.....: 1, 4096, 16384.  
:
- Power supply Vcc.....: 10÷30 VDC
- Max consumption.....: 2,5 Watt
- Light source.....: LED with >= 100000 h life
- Optical sensors.....: IR photodiodes array
- Step frequency LSB....: 800 kHz
- Operating temperature..: -40 ÷ +85 °C
- Storage temperature...: -40 ÷ +85 °C
- Humidity.....: 98% (without liquid state)
- Bus connection.....: CAN transceiver (ISO 11898)
- Status indic. with 2 LEDs
- Accuracy of divisions..: ±½ LSB(<13bit), ±2 LSB(13÷16bit)
- Output interface.....: (C2) CANopen / CAN  
(CF) CAN Fiber optic

- Connections : For the codes and the descriptions of connectors see 'ORDERING CODE' on page 2.
- Housing.....: Aluminium (\*)
- Weight.....: singlet.550g ,multit. 600 g
- Shaft.....: Stainless steel
- Max radial/axial load.: 40/110 N
- IP output side.....: see 'CONNECTIONS' on page 2
- IP shaft side.....: std.64 | sealed 66
- Contin. max RPM...(\*\*): 6000 | 3000
- Starting torque..gcm.: 50 | 90
- Impact resistance.....: 30 G (11 ms)
- Vibration resistance...: 10 G (10 ÷ 1000 Hz)
- Ball bearings life....: >10^5 h @ 1000 rev./m
- SMD technology
- Polarity inversion protect.
- Over voltage peak protect.
- Disc made of unbreakable and durable plastic.
- EMC certific. according to EN 61000-6-2, EN 61000-6-4
- Max.transmis. rate 1 Mbaud

(\*) Custom options.

(\*\*) Intermittent max RPM + 30% of continuous max RPM.

**POSSIBLE OPTIONS**

CODE	DESCRIPTION	CODE	DESCRIPTION	CODE	DESCRIPTION
Q	All stainl. steel	W	Sealed ball bear.	X	Customer options



ELCIS s.r.l. Via Rosa Luxembourg 12/14 10093 COLLEGNO (TO) ITALY  
Phone: +39 011 715577/78 r.a.  
MAIL: ELCIS s.r.l. P.O.Box 90 10093 COLLEGNO (TO) ITALY

\* <http://www.elcis.com>  
\* e-mail: [info@elcis.com](mailto:info@elcis.com)  
\* Fax: +39 011 712613

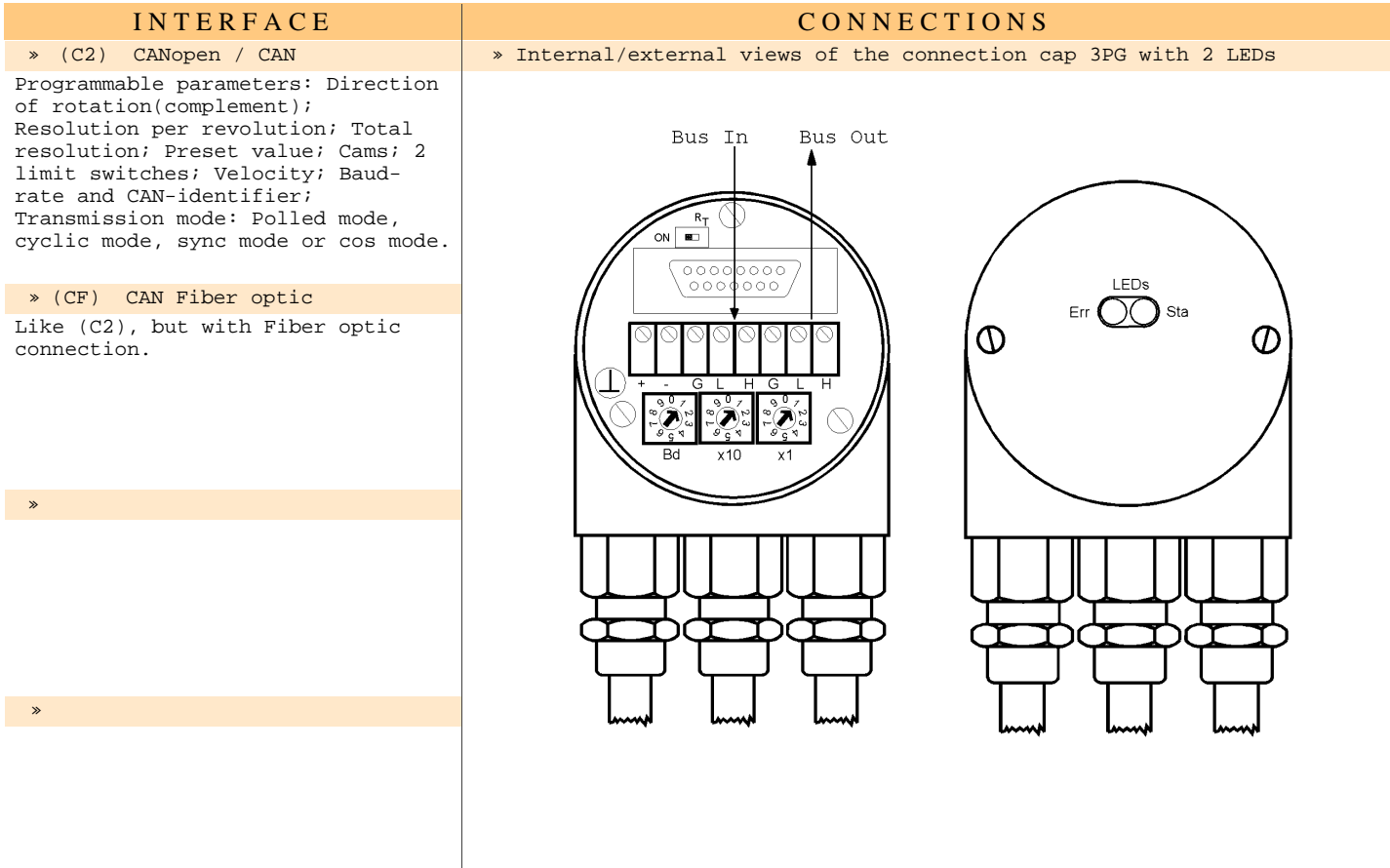

### ORDERING INFORMATION

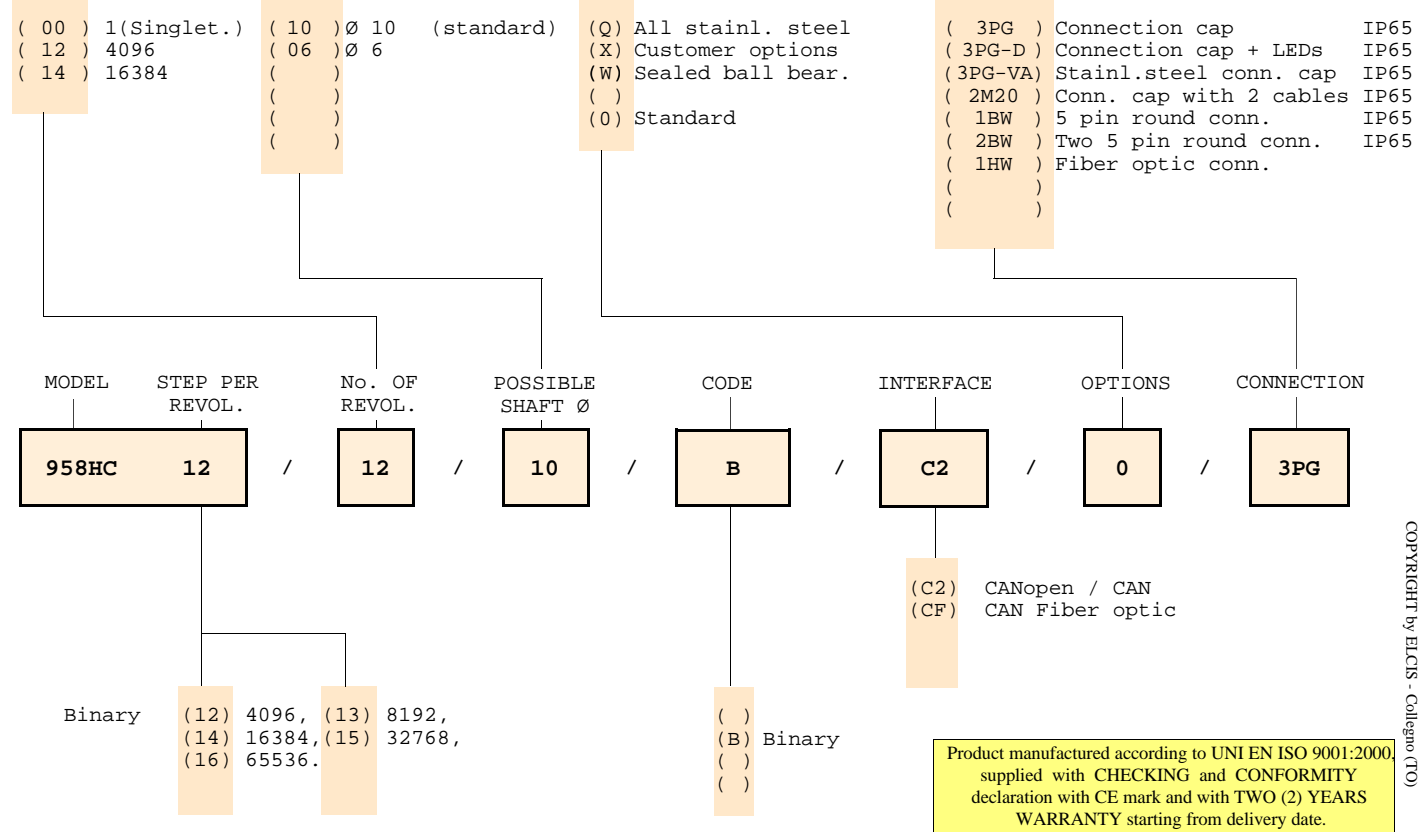

COPYRIGHT by ELCIS - Collegno (TO)

	ELCIS s.r.l. Via Rosa Luxembourg 12/14 10093 COLLEGNO (TO) ITALY Phone: +39 011 715577/78 r.a. MAIL: ELCIS s.r.l. P.O.Box 90 10093 COLLEGNO (TO) ITALY	* <a href="http://www.elcis.com">http://www.elcis.com</a> * e-mail: <a href="mailto:info@elcis.com">info@elcis.com</a> * Fax: +39 011 712613
--	--	--