



# elap TM + MP200

## MAGNETIC TRANSDUCER

The linear magnetic measuring system **TM+MP200** is composed by the magnetic transducer **TM** and the magnetic band **MP200**: The transducer works contactless, relieving the polarized fields of the magnetic band and converting the measure into digital signals.

The system can be profitably employed in severe industrial environments, in presence of water, oil, grease. The mounting method is easy and cheap and the measure is accurate and repeatable.

The scanning head **TM** is contained in a compact and strong metal case, and it is available with reading resolution 0.1 mm (**TM10**) or 0.01 mm (**TM100**).

An electronic zero pulse is generated each 4 mm (type **TM10C/TM100C**), or matching with one or more external magnets (**TM10E/TM100E**).

**Complying with CE standards**

### READING TRANSDUCER SPECIFICATIONS

TYPE	TM10C/TM10E	TM100C/TM100E
<i>Reading resolution</i>	0.1 mm	0.01 mm
<i>Accuracy</i>	± 0.1 mm/m	± 0.05 mm/m
<i>Electronic zero pulse</i>	each 4 mm (type C) or matching with external magnet (type E)	
<i>Frequency</i>	300 KHz	
<i>Sensor distance</i>	0.3 ÷ 1.2 mm	
<i>Phase difference</i>	90° ± 5° electrical degree	
<i>Max. speed</i>	12 m/s	
<i>Vibration resistance</i>	(55 Hz ÷ 2 KHz) at 300 m/s <sup>2</sup>	
<i>Shock resistance</i>	1000 m/s <sup>2</sup> (11 m/s)	
<i>Protection degree</i>	IP67	
<i>Operating temperature</i>	0 ÷ 50° C	
<i>Stocking temperature</i>	-20° ÷ 80° C	
<i>Humidity</i>	100% non condensed	
<i>Supply</i>	5/28 Vdc ±5% 60 mA no load	
<i>Output signals</i>	push-pull or line-driver	
<i>Standard cable</i>	length 2 m	
<i>Electrical protections</i>	for the supply: against polarity inversions for the outputs: against short circuits	

### MAGNETIC BAND MP200

The magnetic band **MP200** consists of a plasto-ferrite strip, which is polarized at regular distance, and supported by a stainless steel carrier; it is equipped with the adhesive tape for an easy mounting.

As an optional, the magnetic band can be supplied with a magnetically transparent stainless steel cover for physical protection.

### MAGNETIC BAND SPECIFICATIONS

<i>Pole pitch</i>	2 + 2 mm
<i>Accuracy</i>	±50 µm/m
<i>Width</i>	10 mm
<i>Thickness</i>	1.3 mm
<i>Max. length</i>	50 m
<i>Thermal expansion</i>	10.5x10 <sup>-6</sup> °C <sup>-1</sup> ref.t.=20°C±0.1°C
<i>Operating temperature</i>	0 ÷ 70°C
<i>Stocking temperature</i>	-20° ÷ 80°C

### DIMENSIONS

Magnetic Transducer **TM** + Magnetic Band **MP200**

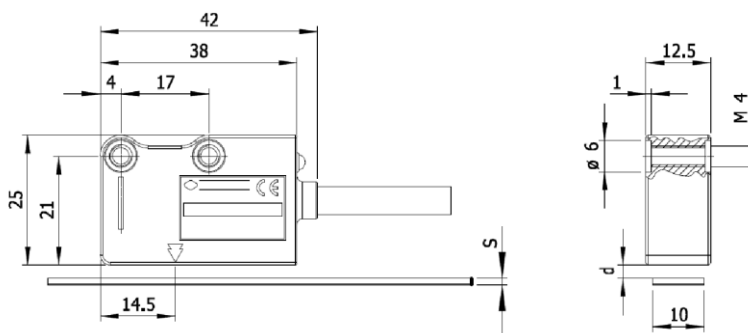

d = sensor distance: 0.3 ÷ 1.5 mm



ELAP VIA VITTORIO VENETO, 4 · I-20094 CORSICO (MI) · TEL. +39.02.4519561  
FAX +39.02.45103406 · E-MAIL INFO@ELAP.IT · SITE WWW.ELAP.IT