

This probe measures electrical conductivity and TDS using the inductive method.

Thanks to the analog and digital outputs, the probe can be connected to the most common PLC's or data acquisition boards.

B&C Electronics offers MC 6587 and MC 7687 multi-channel controllers that allow complete management of up to three probes, displaying the measurements and the messages that guide calibration and configuration.

Main features

Ranges

The conductivity ranges are configurable from 4 mS to 2000 mS. The TDS scales are configurable from 10.00 ppt to 1000 ppt. It is also possible to associate a scalability factor from 10% to 100% to obtain intermediate full-scale values on the 4/20 mA current loop through digital commands.

TDS

The probe is configurable for TDS measurement. If connected to MC 7687 - MC 6587, or through digital commands, the user can set a conversion factor specific to his application.

Operating mode

The probe can be configured to operate in analog or digital mode. If connected to a master device it is possible to carry out several operations through specific digital commands.

Analog output

The 4/20 mA current loop is proportional to the main measurement value. The current loop is galvanically isolated, for the interface to PLC or data acquisition boards.

Serial interface

The RS485 isolated serial interface allows for calibration and configuration of the probe, the simultaneous transmission of conductivity measurements, TDS and temperature. The boot loader function allows the user to update the probe's firmware.

Communication protocols

The B&C ASCII protocol coexists with the MODBUS RTU protocol (03, 06, 16 function) for the transmission of the measurements, the configuration and calibration of the probe.

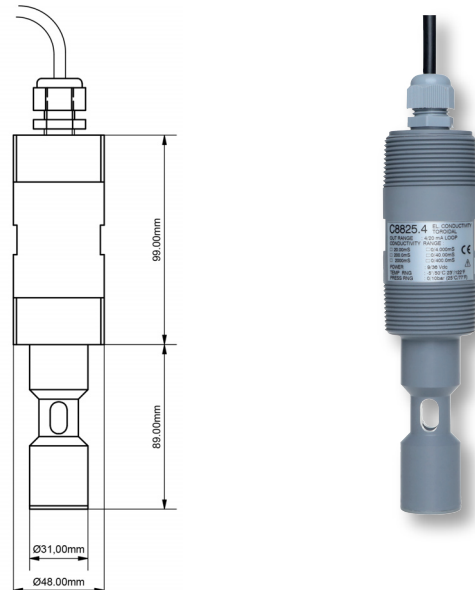

Software filter

A filter software operates on the sensor input signal with two selectable time constants. In order to obtain good reading stability and fast response to the changes in the process, the user can set the response time for both the small or large variation signals.

Temperature compensation

The probe includes a temperature sensor for automatic compensation. The reference temperature and the temperature coefficient value can be selected digitally.

Easy installation

The probe has two ends with a 1.5" MNPT thread and it can be installed directly onto the pipeline. For installation in the tank, SZ 7531 adapter is available to mount the probe to an extension pipe having a 1" GAS thread.

Power supply

The probe is powered with 9/36Vdc voltage on the current loop, supplied by a PLC or data acquisition boards or by a power supply placed in series between the analog output and the acquisition device. Even in digital mode the power is supplied by the current loop.

PC connections

Customers that use the probes in analog mode can also take advantage of the functions available through the digital mode. B&C Electronics offers BC 8701 a RS485/USB converter to connect the probe to a PC. An easy-to-use software, supplied on demand and free of charge, guides the user through configuration and calibration operations.

Measuring method

The toroidal conductivity sensor consists of two windings on toroidal coils, placed side by side, embedded in a plastic material and therefore not in contact with the sample.

A through hole allows the solution to close an imaginary electrical circuit around them.

An alternating voltage is applied to the transmitter coil while a current proportional to the conductivity of the sample is measured on the detector coil.

The TDS value is calculated by applying a programmable conversion factor.

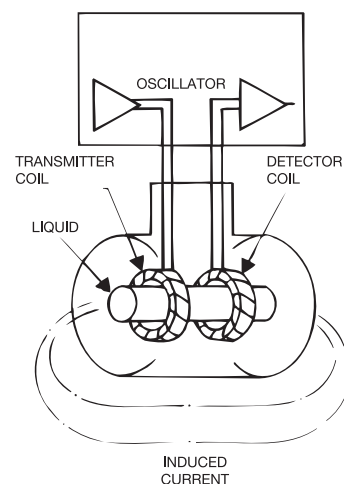

Technical specifications

Conductivity scales:	0/4.000 – 0/40.00 – 0/400.0 mS e 0/20.00 – 0/200.0 – 0/2000 mS
TDS scales:	0/2.000 – 0/20.00 – 0/200.0 ppt e 0/10.00 – 0/100.0 – 0/1000 ppt
TDS/EC factor:	0.450/1.000 1/S
Scalability factor 4/20 mA:	10/100 %
Sensitivity:	60/160 %
Zero:	± 10 % of the full-scale
Resolution:	1 digit
Temperature limit:	- 5/+50 °C
Reference temperature:	20/25 °C
Temperature coefficient:	0.00/3.50 %/°C
Dual filter software:	2/220 seconds
Power supply:	9/36Vdc
Current loop:	4/20 mA isolated
Load:	600 Ohm max. a 24Vdc
Digital output:	RS 485 isolated
Protocols:	B&C ASCII and Modbus RTU (03, 06, 16 functions)
Baud rate:	2400 / 4800 / 9600 / 19200 baud
Probes ID:	01/99 (B&C protocol) 01/243 (Modbus protocol)
Probes network:	32 max.
Operating temperature:	60 °C max.
Operating relative humidity:	95 % without condensation
Operating pressure:	10 bar at 25 °C / 5 bar at 50 °C
Dimensions:	L=165 mm, D=60 mm
Thread/connection:	1.5" MNPT
Body:	PVC-C
Weight:	Body 520 g, cable 640 g
Cable:	10 m (100 m max.), PVC sheath
Protection:	IP 68
EMC/RFI conformity:	EN 61326-2-3/2013 – EN55011/2009

The technical specifications could be changed without notice.

Applications

- Food and beverage
- Paper and Pulp
- Chemical Industry
- Pharmaceutical Industry
- Electroplating
- Printing Industry
- Textile Industry
- Fertirrigation
- Drinking water
- Cooling Towers
- Waste Water Treatment
- Surface treatment