

ECL

POWER SAVING DEVICE FOR ON-OFF SOLENOID VALVES SERIES 20



PLUG VERSION

OPERATING PRINCIPLE

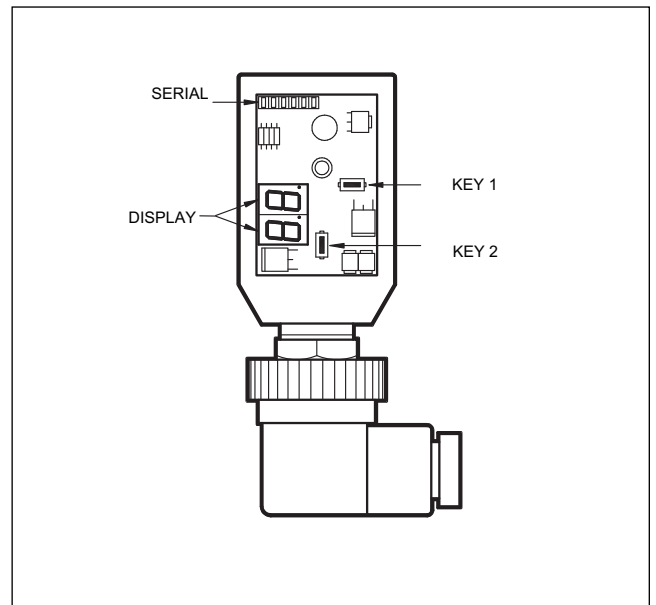
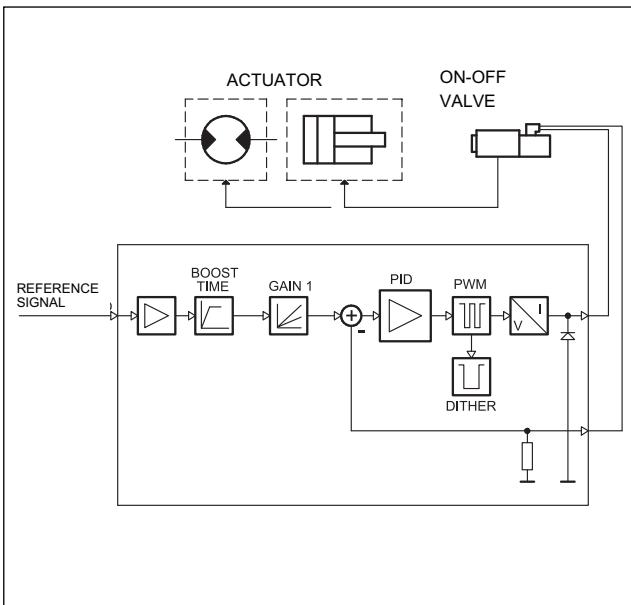

TECHNICAL CHARACTERISTICS

Power supply	V DC	8 + 30 Ripple included
Max current	A	2,60
Absorbed current with valve not switched	mA	40
Current absorbed by the switching command (at 30 VDC)	mA	10 max
Full power feeding time	ms	50
Holding current regulating range	% I MAX	50 ÷ 100
Holding current default	% I MAX	40
Connector type		EN 175301-803 (ex DIN 43650)
Electromagnetic compatibility (EMC) - emissions IEC EN 61000-6-4 - immunity IEC EN 61000-6-2		according to 2014/30/EU standards (see paragraph 5 - NOTE)
Protection to atmospheric agents		IP 65/67
Operating temperature range	°C	-20 / +70
Mass	kg	0,10

1 - IDENTIFICATION CODE

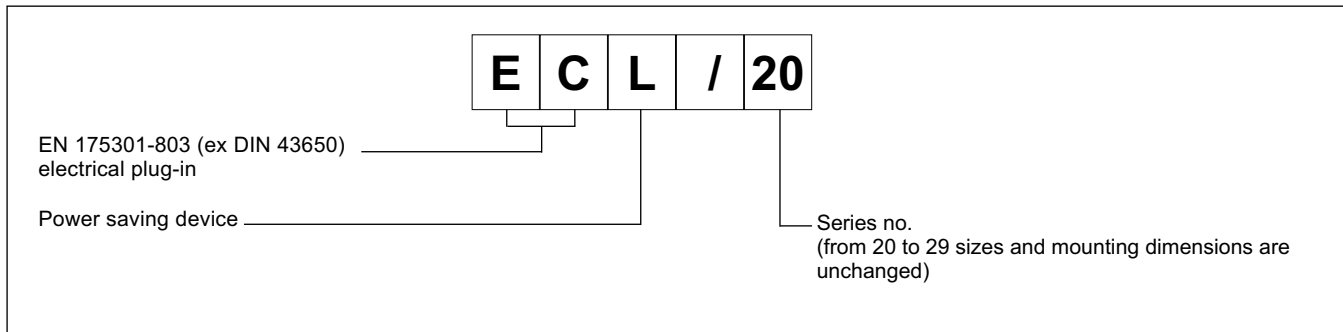

The ECL connector is a digital amplifier controlling open loop on-off valves directly from PLC.

The unit supplies a set current independently from temperature variations or load impedance.

Setting is possible by buttons and display inside the case, or with a PC by RS232 with the software EDC-PC/10, (see paragraph 6.2).

2 - FUNCTIONAL SPECIFICATIONS

2.1 - Electric power supply

The connector requires a power supply of 24V DC (pin 1 and 2). The power supply voltage must be rectified and filtered, and it has not to be higher than 6A.

NOTE: The value of the power supply voltage on the connector must be higher than the rated working voltage of the solenoid to be controlled.

The power required by the card depends on the power supply voltage and on the maximum value of the supplied current.

2.2 - Electrical protection

The connector is protected against overvoltage and polarity inversion. On the output a protection against any short circuit is foreseen.

2.3 - Functioning

This device operates by feeding the solenoid valve at the max current value for a time sufficient to guarantee the complete valve energizing (50 ms). The current is therefore automatically reduced at holding.

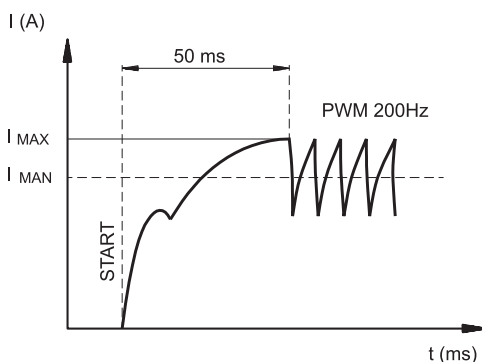

default values: I_{MAN} = 1A
threshold : 200 mV
freq: 200 Hz

I_{MAX} = max current
I_{MAN} = holding current

3 - SIGNALS

3.1 - POWER ON (Power supply)

Displays indicate the connector is ON and with +24 V DC.

4 - ADJUSTMENTS

There are two way adjustments: variables view and parameters editing. The first one enables the real time monitoring of the control values, for both required and read current, on both channels. The second modality enables the operating parameters view and editing.

4.1 - Variables view

The card is switched on at the variables view modality, and it shows the first variable value, that is the C1 parameter, current solenoid.

- C1: current supplied from ECL to the solenoid read on real time
- U1: Threshold reference signal.
9.9 = Threshold active

4.2 - Parameters editing

To access the parameter editing, press the key (2) for at least 3 seconds.

The first parameter displayed is G1. To modify it, press the key (1) for two seconds, until the display starts blinking. Use the key (2) to increase the value and the key (1) to decrease it. To save the new value, press both the keys. The display stops blinking.

Pressing the key (2) again is possible to scroll all the parameters. To modify the other parameters, repeat the steps above-mentioned for the G1 parameter.

The variables that can be selected are:

- G1:** "I Max" current, expressed in milliAmpere.
It sets the maximum current to the solenoid, when the reference signal is at the maximum value. It is used to limit the maximum value of the supplied current.
Default value of I_{max} = 1000 mA
Range = 50 ÷ 100% of I_{max}
- Fr:** PWM frequency, in Hertz.
It sets the PWM frequency, which is the pulsating frequency of the solenoid current.
Default value = 200
Range = 100 ÷ 500 Hz

DISPLAY VIEW EXAMPLE:

REFERENCE (V)	VARIABLE (V)	U1	VARIABLE C1
0	00		40. (mA)
10	10.		2.6 (A)

5 - INSTALLATION

The connector type electronic unit is suitable for direct assembly on the solenoid of the relative on-off valve. With the 4-core connector for supply and for the reference signal.

NOTE: To observe EMC requirements it's important that the control unit electrical connection is in compliance with the wiring diagram of chapter 7.

As a general rule, the valve and the electronic unit connection wires must be kept as far as possible from interference sources as power wires, electrical motors, inverters and electrical switches.

In environments where there are critical electromagnetic interferences, a complete protection of the connection wires can be requested.

6 - START UP, CONTROL SETTINGS AND SIGNAL

6.1 - Set up

Settings can be changed by either acting on the (1) and (2) keys located on the card front panel, or using the EDC-PC software kit.

6.2 - EDC-PC/10 Software (code 3898301001)

The relevant hardware and software kit (to be ordered separately) allows to read the values and to set the connector easily.

The software communicates, through a flat cable, to the ECL; the connector is behind the protecting gate.

The EDC-PC/10 software compatibility is guaranteed only on Windows XP® operating systems.

7 - WIRING DIAGRAM

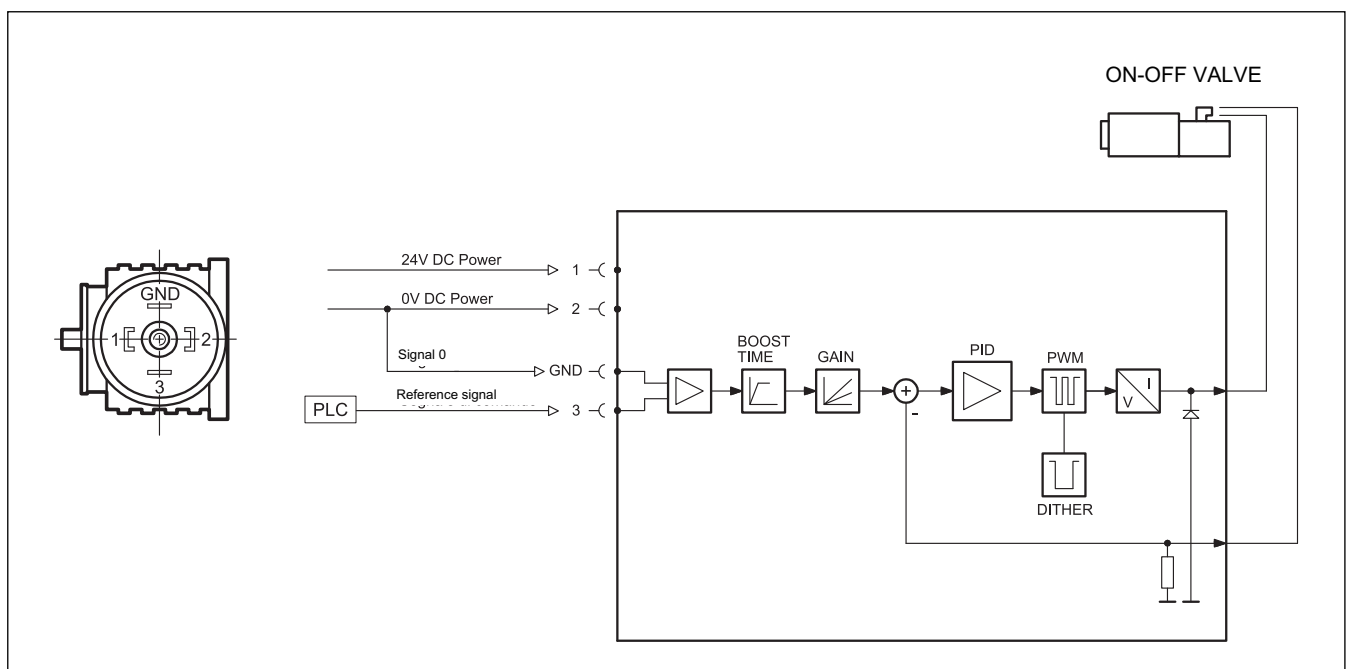

8 - OVERALL AND MOUNTING DIMENSIONS

